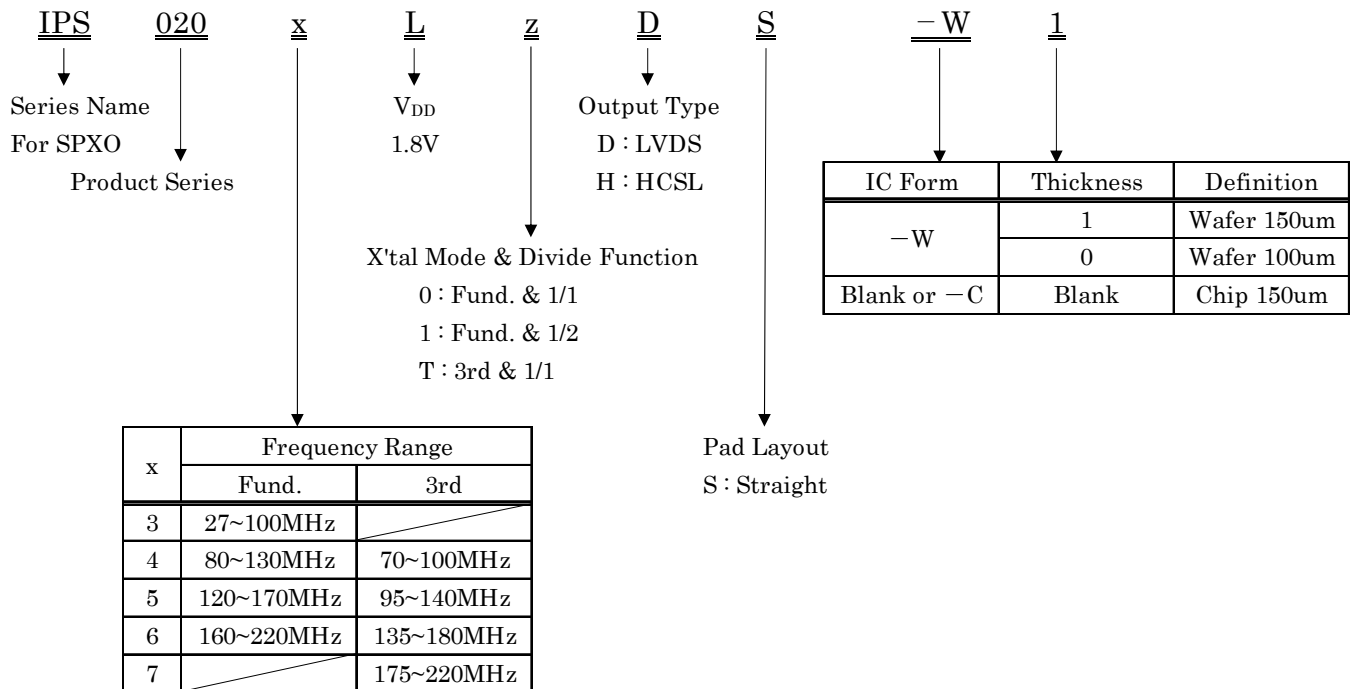

■ Description

IPS020*L is the IC for differential output SPXO corresponding to the fundamental crystal from 27MHz to 220MHz, and operation voltage is 1.71V minimum. 3rd overtone oscillation is also available.

■ Features

- Operation temperature : -40°C~125°C
- Power supply voltage : 1.71V~1.89V
- Standby function : Oscillation stop
- Crystal frequency : 27MHz~220MHz
- Output : LVDS & HCSL
- Crystal mode : Fundamental & 3rd overtone
- Small chip size : 0.65mm × 0.75mm
- Pad layout : Straight type
- Duty cycle : Within 50%±5%

1. Part number rule

2. Series

Part Number	Output	Crystal Frequency (MHz)			Divide	Output Frequency (MHz)		Remarks
		Mode	Min.	Max.		Min.	Max.	
IPS020 3 L 0 D S	LVDS	Fund.	27	100	1/1	27	100	
IPS020 3 L 1 D S					1/2	13.5	50	
IPS020 4 L 0 D S			1/1	80	130	80	130	
IPS020 5 L 0 D S				120	170	120	170	
IPS020 6 L 0 D S				160	220	160	220	
IPS020 3 L 0 H S	HCSL	Fund.	27	100	1/1	27	100	
IPS020 4 L 0 H S						80	130	80
IPS020 5 L 0 H S			120	170		120	170	
IPS020 6 L 0 H S			160	220		160	220	
IPS020 4 L T D S	LVDS	3rd	70	100	1/1	70	100	
IPS020 5 L T D S						95	140	95
IPS020 6 L T D S			135	180		135	180	
IPS020 7 L T D S			175	200		175	200	Ta=-40°C~125°C
			175	220		175	220	Ta=-40°C~85°C
IPS020 4 L T H S	HCSL	3rd	70	100	1/1	70	100	
IPS020 5 L T H S						95	140	95
IPS020 6 L T H S			135	180		135	180	
IPS020 7 L T H S			175	200		175	200	Ta=-40°C~125°C
			175	220		175	220	Ta=-40°C~85°C

Please contact us for other models.

3. Absolute Maximum Ratings

V_{SS}=0V, Ta=25°C± 2°C

Parameter	Symbol	Condition	Ratings		
			Min	Max	Unit
Supply Voltage	V _{DD}		V _{SS} -0.5	5.0	V
Input Voltage	V _{IN}	All Input Pin	V _{SS} -0.5	V _{DD} +0.5	V
Output Voltage	V _{OUT}		V _{SS} -0.5	V _{DD} +0.5	V
Output Current	I _{OUT}			25	mA
Junction Temperature	T _j		-55	150	°C
Storage Temperature	T _{stg}		-55	125	°C

4. Recommended Operating Condition

 $V_{SS}=0V, T_a=-40^{\circ}C\sim 125^{\circ}C$

Parameter	Symbol	Condition	Min	Typ	Max	Unit	Note
Supply Voltage	V_{DD}		1.71	1.80	1.89	V	V_{DD}
“H” Input Voltage	V_{IH}		$V_{DD}\times 0.7$			V	CE
“L” Input Voltage	V_{IL}				$V_{DD}\times 0.3$	V	CE
Input Voltage	V_{IN}		V_{SS}		V_{DD}	V	CE
Output Load Resistance	RL	LVDS ※1	99	100	101	Ω	OUT
		HCSL ※2	49.5	50.0	50.5		
Ambient Temperature	T_{opt}		-40		125	°C	
		IPS0207MT, ~220MHz	-40		85		

This IC has enough immunity against ESD and Latch-up, but handle with care.

※1 Between OUT and OUTN ※2 To GND and $R_s=0\Omega$

5. Electrical Specification

5-1 LVDS Output

5-1-1 DC Characteristics

 $Unless\ otherwise\ stated, V_{DD}=1.71V\sim 1.89V, V_{SS}=0V, T_a=-40^{\circ}C\sim 125^{\circ}C$

Parameter	Symbol	Condition	Specification			Unit	
			Min	Typ	Max		
Output leak current	I_z	CE=0.3V			10	μA	
“L” input current	I_{IL}	$V_{IN}=V_{SS}$		-10		μA	
“H” output voltage	V_{OH}	RL=100Ω(Between OUT & OUTN) CE=Open, OUT/OUTN		1.43	1.60	V	
“L” output voltage	V_{OL}		0.90	1.10		V	
Differential voltage	V_{OD}		247	330	454	mV	
Differential voltage deviation	ΔV_{OD}				50	mV	
Offset voltage	V_{OS}		1.125	1.250	1.375	V	
Offset voltage deviation	ΔV_{OS}				50	mV	
Current consumption※	I_{DD}		IPS0203L0DS, F0=100MHz		5.5	11.0	mA
			IPS0204L0DS, F0=122.88MHz		6.0	12.0	
		IPS0205L0DS, F0=170MHz		7.0	14.0		
		IPS0206L0DS, F0=212.5MHz		7.0	14.0		
		IPS0204LTDS, F0=92.17MHz		6.5	13.0		
		IPS0205LTDS, F0=125MHz		7.0	14.0		
		IPS0206LTDS, F0=156.25MHz		7.5	15.0		
IPS0207LTDS, F0=200MHz		9.0	18.0				
Current consumption at oscillation stop	I_{DDD}	CE≤0.3V			10	uA	

※Condition : $V_{DD}=1.8V, CE=Open, RL=100\Omega$ (Between OUT & OUTN)

5-3-2 Switching Characteristics

 Unless otherwise stated, $V_{DD}=1.71V\sim 1.89V$, $V_{SS}=0V$, $T_a=-40^{\circ}C\sim 125^{\circ}C$

Parameter	Symbol	Condition	Specification			Unit	
			Min	Typ	Max		
Oscillation start up time	Tstart	IPS020xL0, IPS0203L1			2.0	ms	
		IPS020xLT			10		
Output Disable Time	Tplz				200	ns	
Output Enable Time	Tpzl	IPS020xL0, IPS0203L1			2.0	ms	
		IPS020xLT			10		
Rise time / Fall time	Tr / Tf	20%~80% Vopp			0.50	ns	
Output Duty Ratio	Duty	1/2Vopp point	IPS020xL0 IPS0203L1 IPS020xLT (Except x=7)	45		55	%
			IPS0207LT $T_a=-40^{\circ}C\sim 85^{\circ}C$	45		55	
			IPS0207LT $T_a=85^{\circ}C\sim 125^{\circ}C$	40		60	
Output Swing	Vopp		0.25			V	
Freq. V_{DD} deviation	Fvst	$V_{DD}=1.8\pm 5\%$			± 2.0	ppm	

5-2 HCSL Output
5-2-1 DC Characteristics

 Unless otherwise stated, $V_{DD}=1.71V\sim 1.89V$, $V_{SS}=0V$, $T_a=-40^{\circ}C\sim 125^{\circ}C$

Parameter	Symbol	Condition	Specification			Unit
			Min	Typ	Max	
Output leak current	Iz	CE=0.3V			10	μA
“L” input current	IIL	$V_{IN}=V_{SS}$		-10		μA
“H” output voltage	VOH	$R_L=50\Omega$ (To GND), $R_s=0\Omega$	500		1000	mV
“L” output voltage	VOL	CE=Open, OUT/OUTN	-150		150	mV
Current consumption※	IDD	IPS0203LOHS, F0=100MHz		16.5	25.0	mA
		IPS0204LOHS, F0=122.88MHz		17.0	26.0	
		IPS0205LOHS, F0=170MHz		17.5	27.0	
		IPS0206LOHS, F0=212.5MHz		18.0	27.0	
		IPS0204LTHS, F0=92.17MHz		17.0	26.0	
		IPS0205LTHS, F0=125MHz		18.0	27.0	
		IPS0206LTHS, F0=156.25MHz		18.5	28.0	
IPS0207LTHS, F0=200MHz		19.0	29.0			
Current consumption at oscillation stop	IDDD	CE \leq 0.3V			10	μA

 ※Condition : $V_{DD}=1.8V$, CE=Open, $R_L=50\Omega$ (To GND), $R_s=0\Omega$

5-2-2 Switching Characteristics

 Unless otherwise stated, $V_{DD}=1.71V\sim 1.89V$, $V_{SS}=0V$, $T_a=-40^{\circ}C\sim 125^{\circ}C$

Parameter	Symbol	Condition	Specification			Unit	
			Min	Typ	Max		
Oscillation start up time	Tstart	IPS020xL0			2.0	ms	
		IPS020xLT			10		
Output Disable Time	Tplz				200	ns	
Output Enable Time	Tpzl	IPS020xL0			2.0	ms	
		IPS020xLT			10		
Rise time / Fall time	Tr / Tf	20%~80% Vopp		0.30	0.60	ns	
Output Duty Ratio	Duty	1/2Vopp point	IPS020xL0 IPS020xLT (Except x=7)	45		55	%
			IPS0207LT $T_a=-40^{\circ}C\sim 85^{\circ}C$	45		55	
			IPS0207LT $T_a=85^{\circ}C\sim 125^{\circ}C$	40		60	
Output Swing	Vopp		0.5			V	
Freq. V_{DD} deviation	Fvst	$V_{DD}=1.8V\pm 5\%$			± 2.0	ppm	

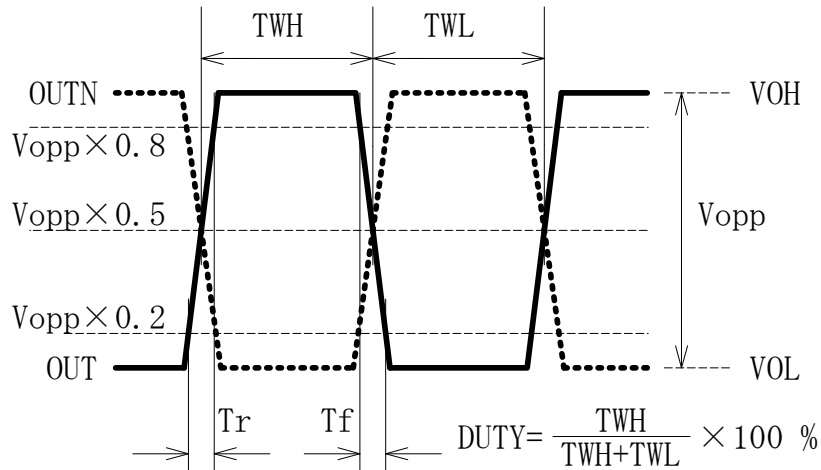

Fig. 5-1 Output Wave Form (Duty, Tr, Tf, VOH, VOL, Vopp) of HCSL

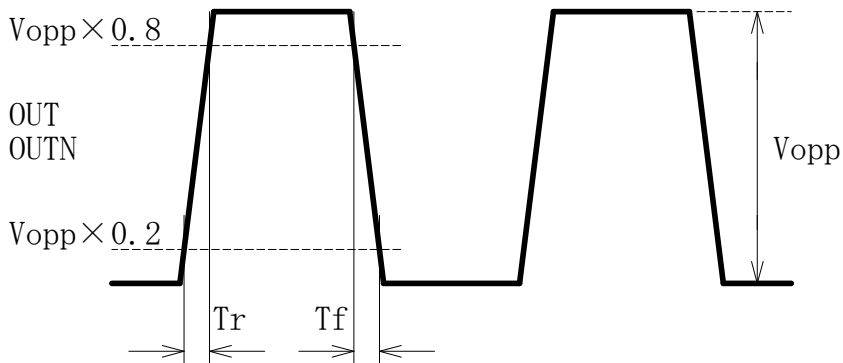
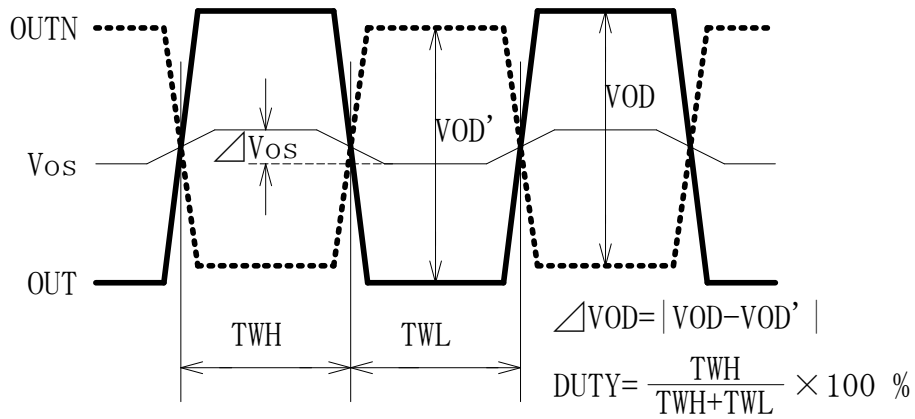
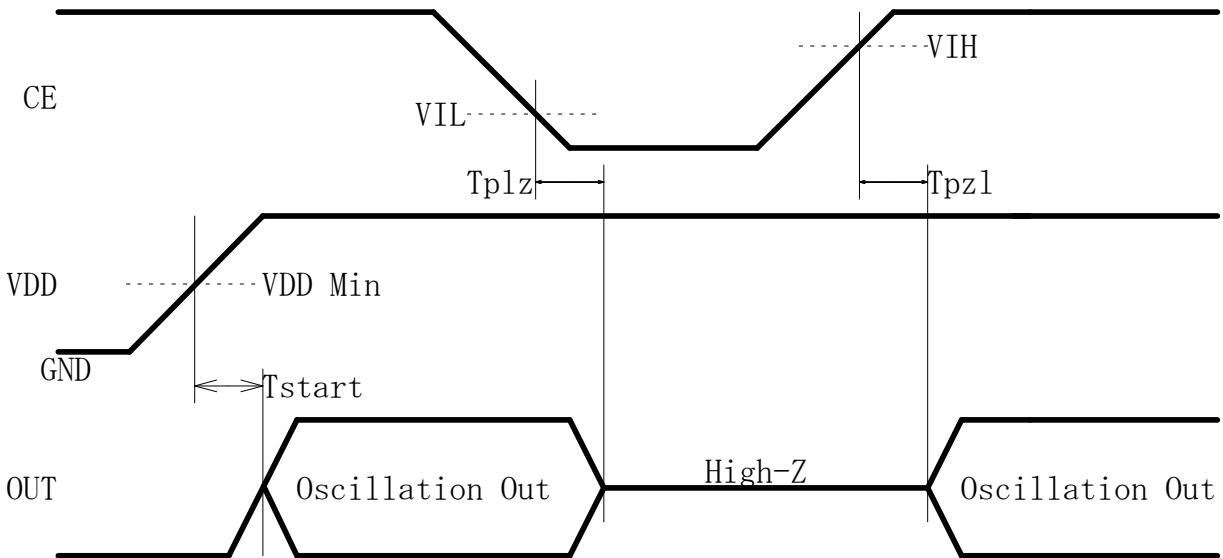

Fig. 5-2 Output Wave Form (Duty, T_r , T_f , V_{OH} , V_{OL} , V_{OD} , V_{OS} , V_{opp}) of LVDS



V_{IH} : Threshold voltage for Oscillation Start
 V_{IL} : Threshold voltage for Oscillation Stop

Fig. 5-3 Input output signal timing

6. Circuit Parameters of Oscillator (Reference Data for Circuit Design)

Ta=25°C

Parameter		Symbol	Condition	Min	Typ	Max	Unit
Feedback Resistor	IPS020xL0 IPS0203L1	Rf	Refer to Fig. 6-1		200		kΩ
	IPS0204LT				2.50		
	IPS0205LT				1.75		
	IPS0206LT				0.75		
	IPS0207LT				0.50		
Driving Resistor	IPS0203L0 IPS0203L1	Rd	Refer to Fig. 6-1		1000		Ω
	IPS0204L0				800		
	IPS0205L0				500		
	IPS0206L0				300		
	IPS0204LT				500		
	IPS0205LT				300		
	IPS0206LT				200		
	IPS0207LT				200		
Oscillation Capacitor	IPS0203L0 IPS0203L1	Cg	Refer to Fig. 6-1		6.0		pF
		Cd			9.0		
	IPS0204L0	Cg			5.0		
		Cd			8.0		
	IPS0205L0	Cg			5.0		
		Cd			7.0		
	IPS0206L0	Cg			4.0		
		Cd			5.0		
	IPS0204LT	Cg			5.0		
		Cd			7.0		
	IPS0205LT	Cg			4.0		
		Cd			7.0		
	IPS0206LT	Cg			3.0		
		Cd			7.0		
	IPS0207LT	Cg			3.0		
		Cd			7.0		

*The above values are the design values and are not guaranteed by test.

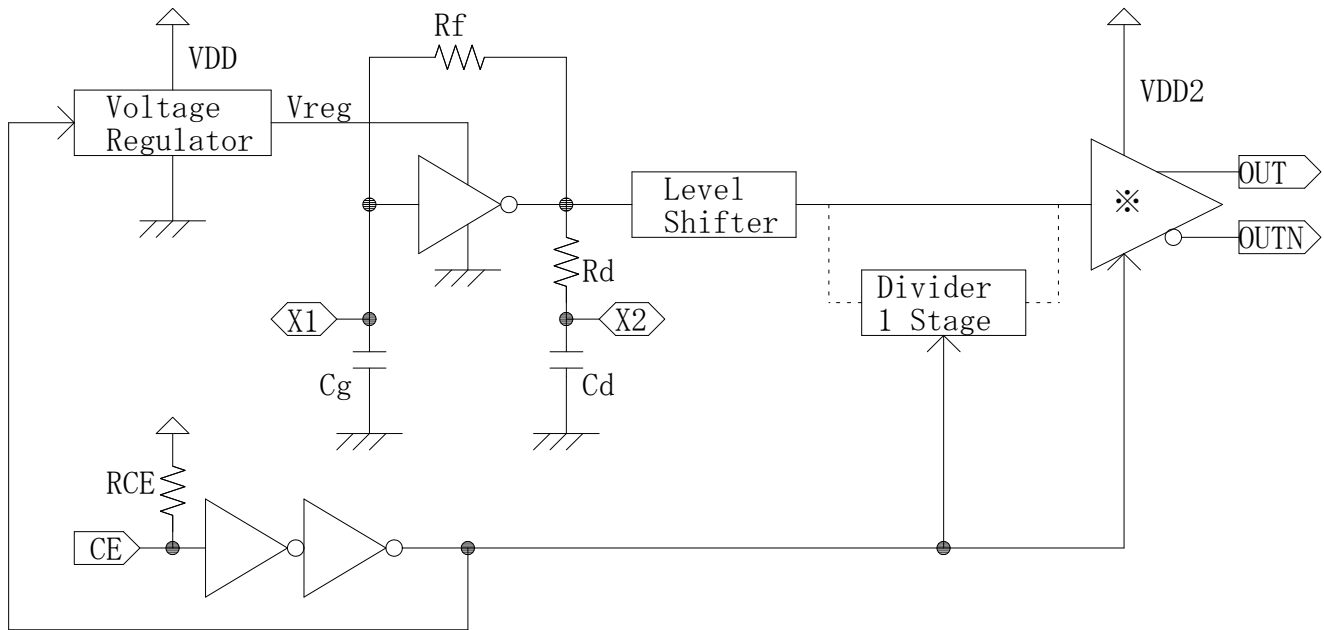

※ Output buffer according to each output waveform format

Fig. 6-1 Block Diagram

7. Pad Layout

7-1 Straight Type

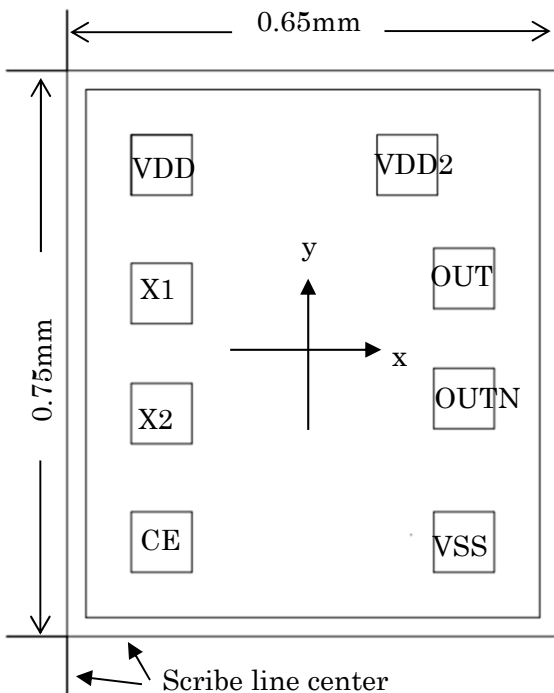

- Die Size: 0.65mm × 0.75mm
- Pad Size: 80um □
- Thickness: 150um ± 20um
- IC Backside: Gnd or Open
- Swapping of OUT/OUTN with wire bond is acceptable

Pad Name	Function	Location (μm)	
		x	y
VDD	(+) Power Supply	-206	256
X1	Crystal Feedback	-206	83
X2	Crystal Drive	-206	-83
CE	Oscillation stop "L": High-Impedance	-206	-256
VSS	(-) Ground	206	-256
OUTN	OUT(Complementary)	206	-65
OUT	OUT(True)	206	108
VDD2	NC is acceptable	113	256
Chip Center		0	0

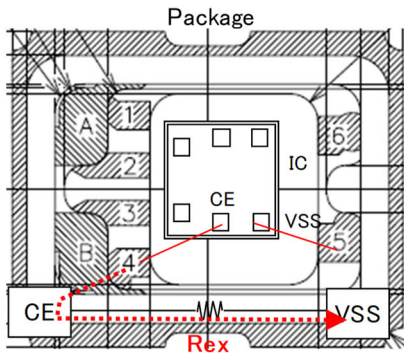

IMPORTANT Notice for CE function

- ※ Oscillation will not be activated when CE=Open after CE=Low if Rex is not large.
- ※ Reference value of Rex is over 10MΩ with CE=Open usage.
- ※ There is no such issue with CE=VDD usage.

Rex : Resistance value between CE and VSS of package

8. IC Part # Identification

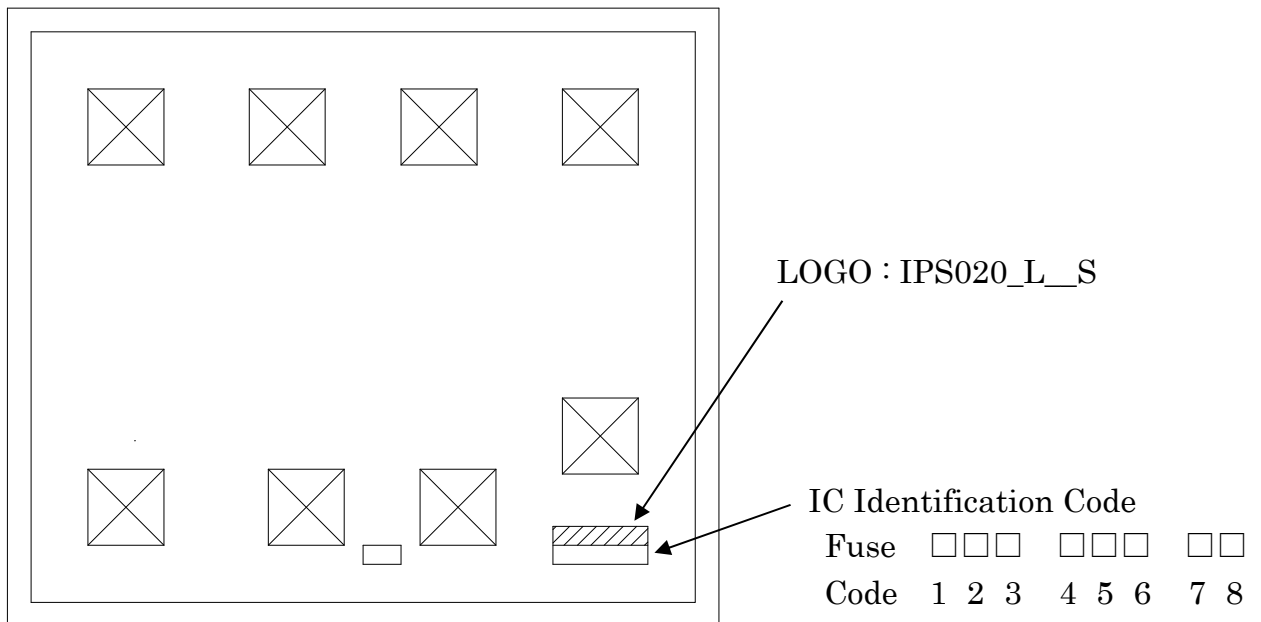

Part #	Code 1~8
IPS0203L0D	<input type="checkbox"/> <input checked="" type="checkbox"/> <input checked="" type="checkbox"/> <input type="checkbox"/> <input type="checkbox"/> <input type="checkbox"/> <input type="checkbox"/> <input checked="" type="checkbox"/>
IPS0204L0D	<input checked="" type="checkbox"/> <input type="checkbox"/> <input type="checkbox"/> <input type="checkbox"/> <input type="checkbox"/> <input type="checkbox"/> <input type="checkbox"/> <input checked="" type="checkbox"/>
IPS0205L0D	<input checked="" type="checkbox"/> <input type="checkbox"/> <input checked="" type="checkbox"/> <input type="checkbox"/> <input type="checkbox"/> <input type="checkbox"/> <input type="checkbox"/> <input checked="" type="checkbox"/>
IPS0206L0D	<input checked="" type="checkbox"/> <input checked="" type="checkbox"/> <input type="checkbox"/> <input type="checkbox"/> <input type="checkbox"/> <input type="checkbox"/> <input type="checkbox"/> <input checked="" type="checkbox"/>
IPS0203L1D	<input type="checkbox"/> <input checked="" type="checkbox"/> <input checked="" type="checkbox"/> <input type="checkbox"/> <input type="checkbox"/> <input checked="" type="checkbox"/> <input type="checkbox"/> <input checked="" type="checkbox"/>
IPS0204LTD	<input checked="" type="checkbox"/> <input type="checkbox"/> <input type="checkbox"/> <input checked="" type="checkbox"/> <input type="checkbox"/> <input type="checkbox"/> <input type="checkbox"/> <input checked="" type="checkbox"/>
IPS0205LTD	<input checked="" type="checkbox"/> <input type="checkbox"/> <input checked="" type="checkbox"/> <input checked="" type="checkbox"/> <input type="checkbox"/> <input type="checkbox"/> <input type="checkbox"/> <input checked="" type="checkbox"/>
IPS0206LTD	<input checked="" type="checkbox"/> <input checked="" type="checkbox"/> <input type="checkbox"/> <input checked="" type="checkbox"/> <input type="checkbox"/> <input type="checkbox"/> <input type="checkbox"/> <input checked="" type="checkbox"/>
IPS0207LTD	<input checked="" type="checkbox"/> <input checked="" type="checkbox"/> <input checked="" type="checkbox"/> <input checked="" type="checkbox"/> <input type="checkbox"/> <input type="checkbox"/> <input type="checkbox"/> <input checked="" type="checkbox"/>

Part #	Code 1~8
IPS0203L0H	<input type="checkbox"/> <input checked="" type="checkbox"/> <input checked="" type="checkbox"/> <input type="checkbox"/> <input type="checkbox"/> <input type="checkbox"/> <input checked="" type="checkbox"/> <input type="checkbox"/>
IPS0204L0H	<input checked="" type="checkbox"/> <input type="checkbox"/> <input type="checkbox"/> <input type="checkbox"/> <input type="checkbox"/> <input type="checkbox"/> <input checked="" type="checkbox"/> <input type="checkbox"/>
IPS0205L0H	<input checked="" type="checkbox"/> <input type="checkbox"/> <input checked="" type="checkbox"/> <input type="checkbox"/> <input type="checkbox"/> <input type="checkbox"/> <input checked="" type="checkbox"/> <input type="checkbox"/>
IPS0206L0H	<input checked="" type="checkbox"/> <input checked="" type="checkbox"/> <input type="checkbox"/> <input type="checkbox"/> <input type="checkbox"/> <input type="checkbox"/> <input checked="" type="checkbox"/> <input type="checkbox"/>
IPS0204LTH	<input checked="" type="checkbox"/> <input type="checkbox"/> <input type="checkbox"/> <input checked="" type="checkbox"/> <input type="checkbox"/> <input type="checkbox"/> <input checked="" type="checkbox"/> <input type="checkbox"/>
IPS0205LTH	<input checked="" type="checkbox"/> <input type="checkbox"/> <input checked="" type="checkbox"/> <input checked="" type="checkbox"/> <input type="checkbox"/> <input type="checkbox"/> <input checked="" type="checkbox"/> <input type="checkbox"/>
IPS0206LTH	<input checked="" type="checkbox"/> <input checked="" type="checkbox"/> <input type="checkbox"/> <input checked="" type="checkbox"/> <input type="checkbox"/> <input type="checkbox"/> <input checked="" type="checkbox"/> <input type="checkbox"/>
IPS0207LTH	<input checked="" type="checkbox"/> <input checked="" type="checkbox"/> <input checked="" type="checkbox"/> <input checked="" type="checkbox"/> <input type="checkbox"/> <input type="checkbox"/> <input checked="" type="checkbox"/> <input type="checkbox"/>

: Fuse no cut

: Fuse cut

